

SX-4300

LH3 Steering Sensor with Torque and Multi-turn Position Output

The LH3 torque and position sensor is ideally suited for demanding Electric Power Steering systems.

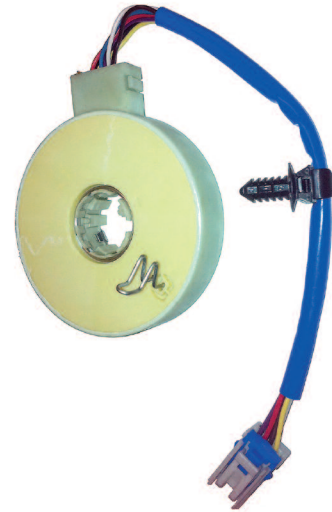

ELECTRICAL¹

Torque Signal Linearity	±3%
Torque Hysteresis	0.5% maximum
Torque Signal Microgradient	1% ±0.6% over 0.2°
Torque Sensed Angle	±8
Position Signal Linearity (P1, P2)	±1.5%
Position Signal Microgradient (P1, P2)	1.111% ±0.4% over 2°
Multi-turn Position Accuracy (P3)	±3%
Multi-turn Position Sensed Angle	±720°
Total Resistance	420 Ω ±30%

MECHANICAL

Torque Mechanical Travel	±11°
Position Mechanical Travel	Continuous
Turning Torque (rotor to rotor)	0.03 NM maximum
Turning Torque (position rotor to housing)	0.06 NM maximum
Weight	95 grams maximum

ENVIRONMENTAL

Operating Temperature Range	-40°C to +85°C
Shock	14 ms half-sine at 300 m/s ²
Vibration	10 to 55 Hz with 1 mm P-P constant displacement, 120 hours each of 3 planes
Torque Rotational Life	1 million cycles
Position Rotational Life	1 million cycles
Storage Temperature Range	-40°C to +105°C

¹ Specifications subject to change without notice. Complete specifications and test methods per BI Technologies specification HEP 32054

SX-4300

OUTPUT CHARTS

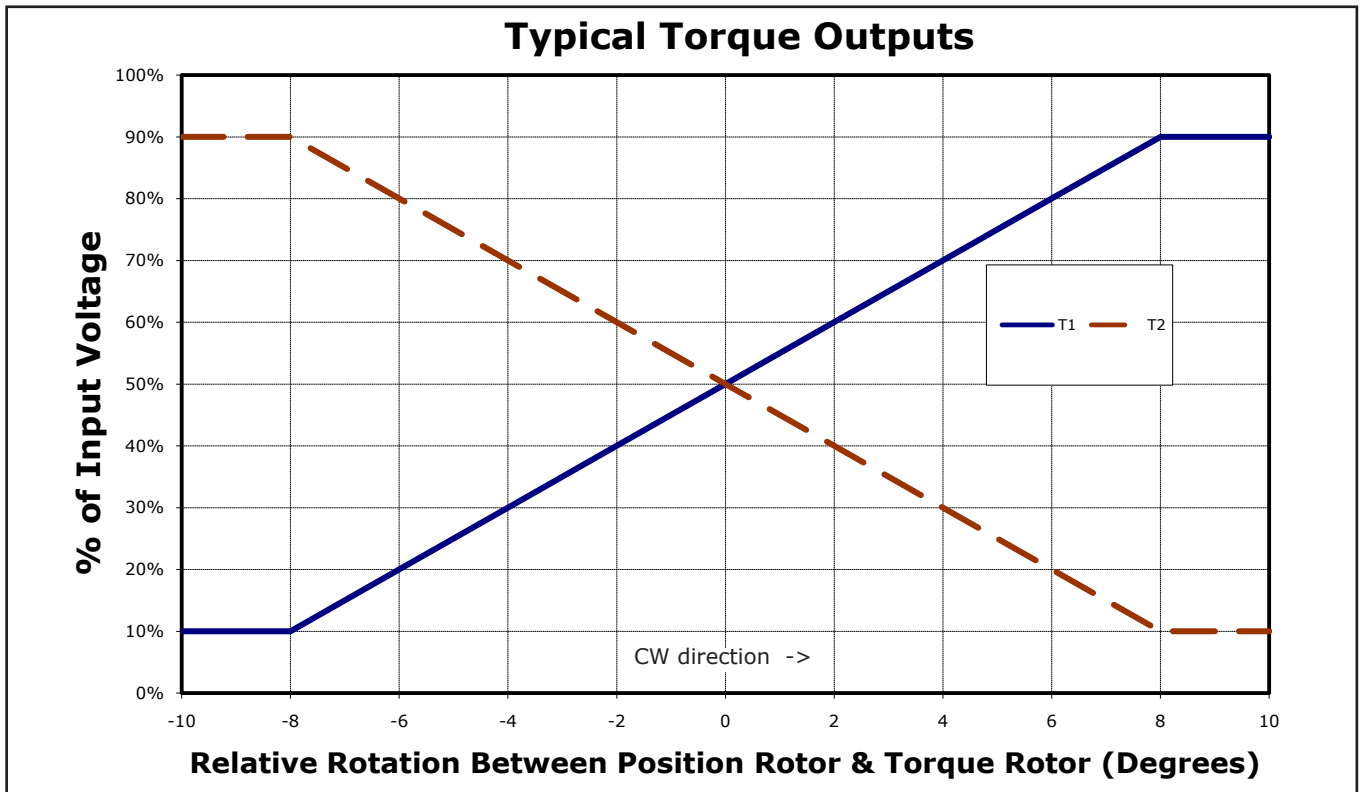
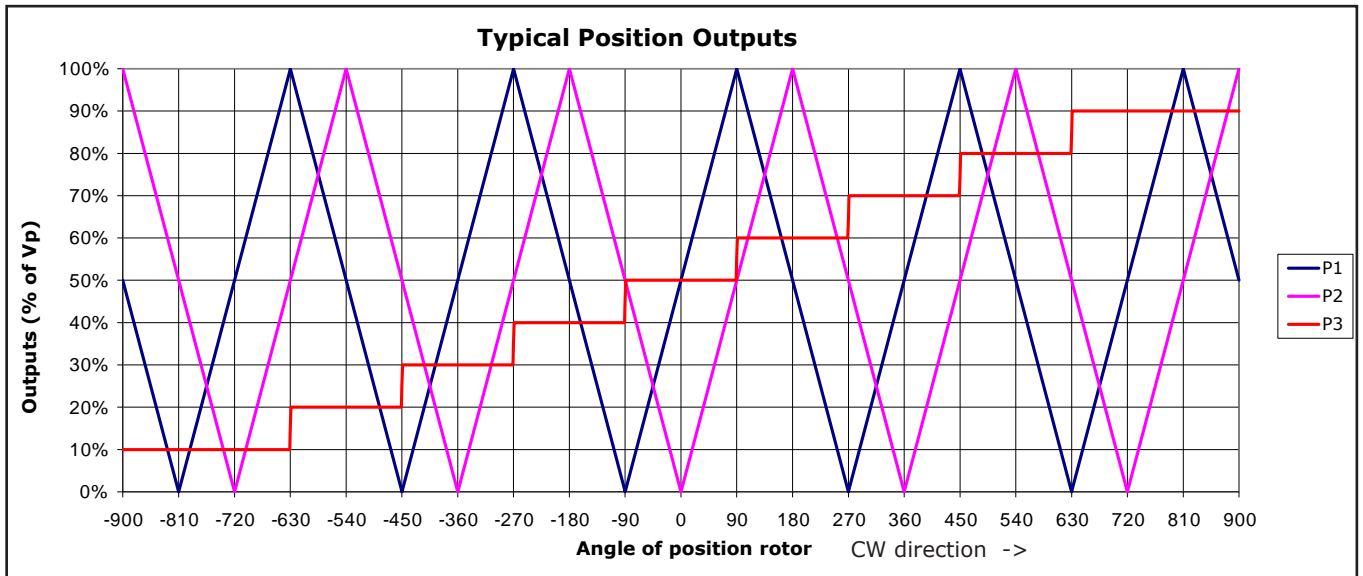

SX-4300

OUTLINE DRAWING

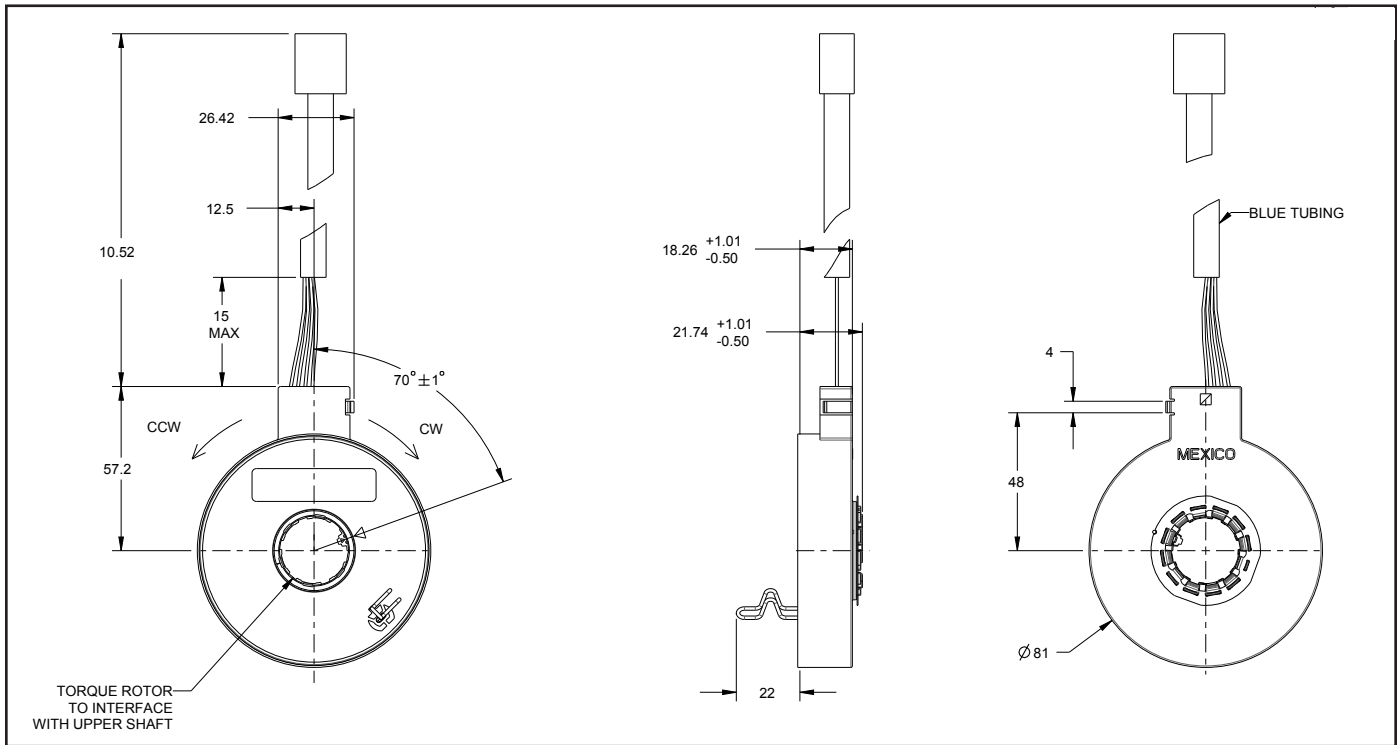

Tolerances ± 0.25 mm unless otherwise specified. See drawing # 122-4300-80 for details.

PINOOTS

PIN OUTS-8 PIN CONNECTOR			
PACKARD 15406142			
4	3	2	1
8	7	6	5

PIN No.	SIGNAL	WIRE COLOR
1	P3	YELLOW
2	P1	BROWN
3	Vcc	RED
4	T2	PURPLE
5	NOT USED	---
6	P2	WHITE
7	GND	BLACK
8	T1	BLUE

SX-4300

RECOMMENDED INTERFACE

